



Up to 240 bar - 57 lpm

**Operation**

The D-DECVR allows free flow (1) to (2) and blocks flow from (2) to (1).

**Symbol**

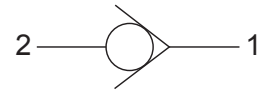

**Features**

- Hardened parts for long life and low leakage.
- Industry common cavity.
- Optional bias springs for backpressure application flexibility.

**Performance**

32 cSc / 38°C.

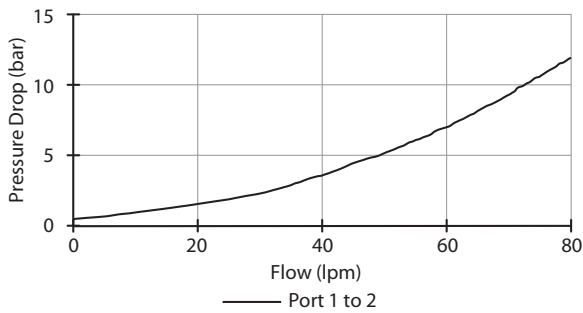

**Specifications**

Nom. Flow (lpm)	57
Max. Pressure (bar)	240
Internal Leakage (32 cSt)	0 to 0.25 cc/min
Hydraulic Oil	General purpose hydraulic fluid
Viscosity Range	3 to 640 cSt
Filtration	ISO 18/16/13
Operating Temp.	-40 to 120°C
Cartridge Torque	41 Nm
Cavity	DE10-2 (see cavity data page <b>CAV-DE10-2</b> )
Spare Seal Kit (Viton)	SK-DDEVHA
Weight - Valve only	0.07 kg
Weight - Valve + Body	0.30 kg (alum) 0.72 kg (steel)

**Dimensions**

[mm]

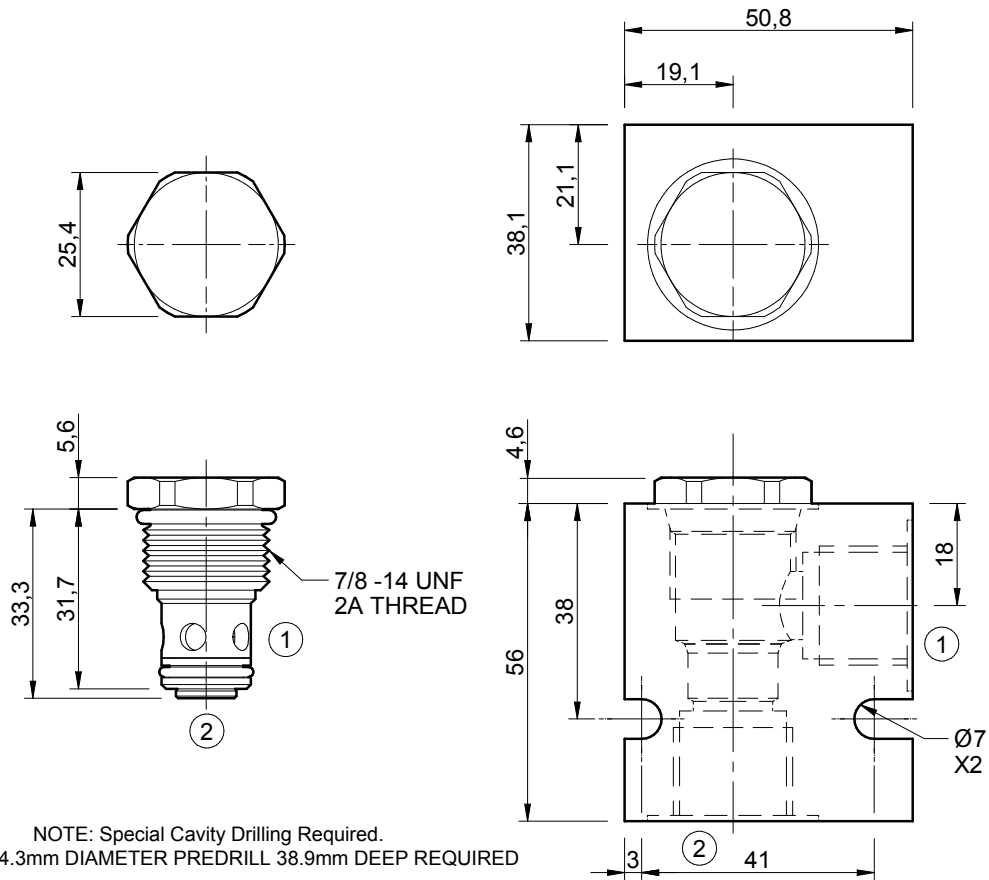

**Ordering Code**

