



Up to 210 bar - 30 lpm

This is a dual pilot operated check valve typically used for blocking or load-holding double acting actuators.

Operation

The D-DGCDP allows flow to pass from (3) to (4) and (2) to (1). The valve blocks flow from (4) to (3) and from (1) to (2). Blocked flow is released when pilot pressure is applied to the port opposite of (3) and / or (2) respectively.

The valve has a 3:1 pilot ratio, so at least 1/3 of the load pressure at port (4) or (1) is required at the pilot line ports (ports (4) or (1) respectively) to open the flow passage to allow flow from port (4) or (1) respectively. The check spring biased at 20 PSI (1.4 bar) to assure holding in the static or no-load conditions

Symbol

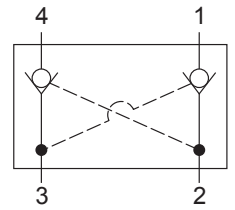

Features

- Hardened parts for long life.
- Industry common cavity.



Great for "in cylinder" use applications.

Performance

32 cSc / 38°C.

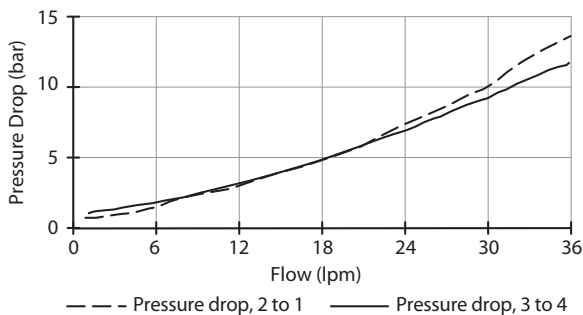

Pressure Drop - Piloted.

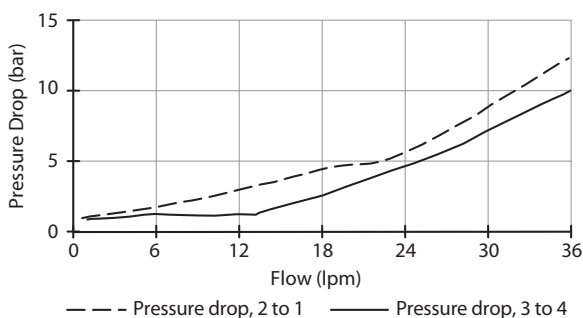

Specifications

Nom. Flow (lpm)	30
Max. Pressure (bar)	210
Pilot Ratio	3:1
Internal Leakage (32 cSt)	0 to 0.25 cc/min at 210 bar
Hydraulic Oil	General purpose hydraulic fluid
Viscosity Range	3 to 640 cSt
Filtration	ISO 18/16/13
Operating Temp.	-40 to 120°C
Cartridge Torque	41 Nm
Cavity	DG10-4 (see cavity data page CAV-DG10-4)
Spare Seal Kit (Viton)	SK-DDGU
Weight - Valve only	0.09 kg
Weight - Valve + Body	0.55 kg (alum) 1.92 kg (steel)

Dimensions

[mm]

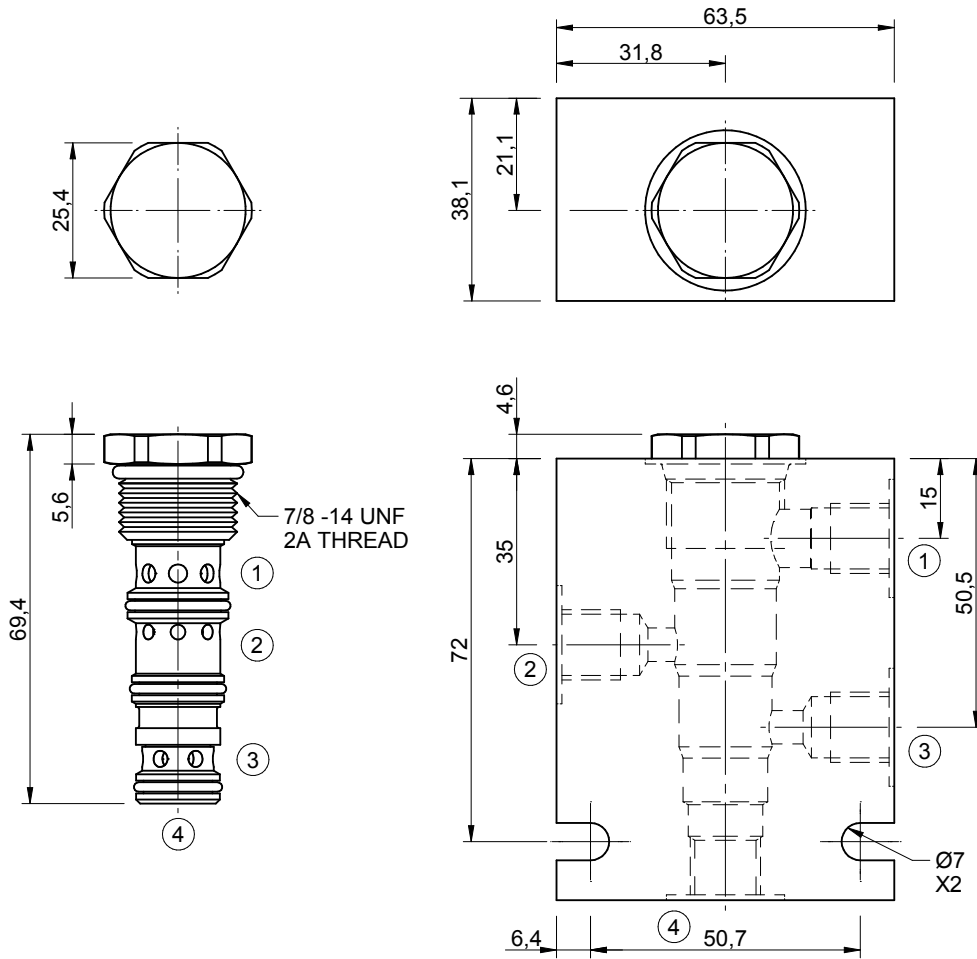

Ordering Code

