



Up to 103 bar - 10 lpm

Operation

The D-MACVS allows free flow (2) to (1) and blocks flow from (1) to (2).

The cartridge has a fully guided poppet, which is spring-biased closed, until sufficient pressure is applied at (2) to open (1).

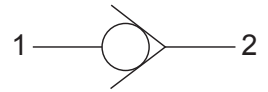
Symbol

Features

- Soft seat for ultra low leakage.
- Industry common cavity.
- Optional bias springs for backpressure application flexibility.
- Fully guided poppet

Performance

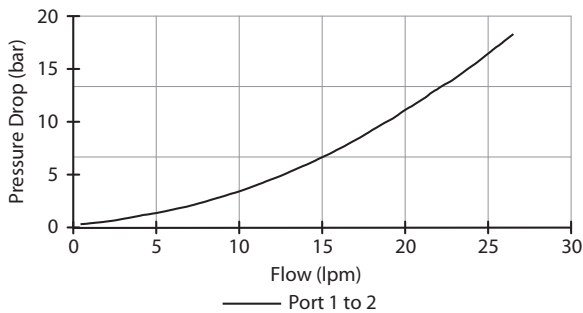
32 cSc / 38°C.

Specifications

Nom. Flow (lpm)	10
Max. Pressure (bar)	103
Internal Leakage (32 cSt)	Negligible
Hydraulic Oil	General purpose hydraulic fluid
Viscosity Range	3 to 640 cSt
Filtration	ISO 18/16/13
Operating Temp.	0 to 70°C
Cartridge Torque	20 Nm
Cavity	MA07-2 (see cavity data page CAV-MA07-2)
Spare Seal Kit (Viton)	SK-DMAVHA
Weight - Valve only	0.03 kg
Weight - Valve + Body	0.17 kg (alum) 0.42 kg (steel)

Dimensions
[mm]

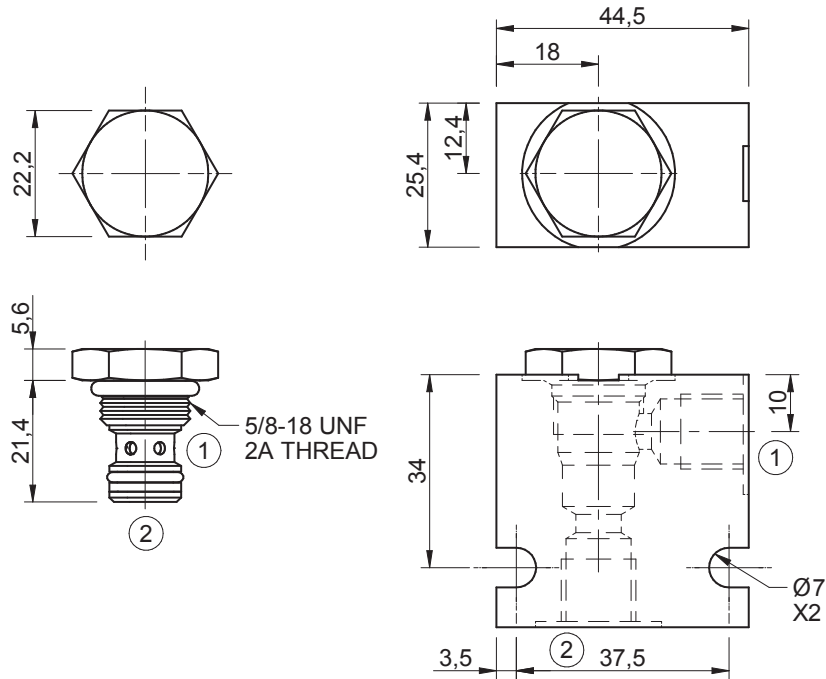

Ordering Code

