

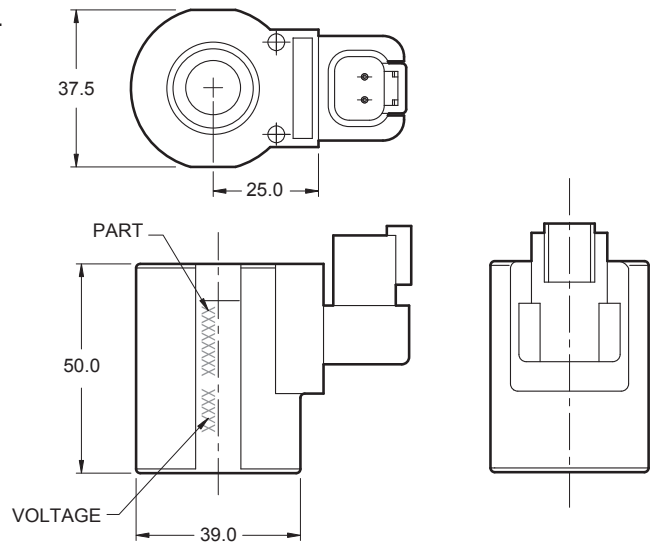

Features

- One piece encapsulated design.
- Weatherproof
- Immersion proof.
- Thermal shock / Dunk tested.
- No external metal shell.



Specifications

Wattage	26 watts nominal
Duty rating	Continuous duty ±10% rated voltage at 49°C ambient
Minimum current for actuation	80% of rated current at room temperature
Magnet wire class	H for all voltages
Temperature range	-40°C to 200°C
Protection degree	IP 69 *(achieved with suitable nut - see note below)
Encapsulating material	Thermo-plastic, resistant to moisture, caustic solutions, fungus and vibrations.
Approx. coil weight	0.22 kg

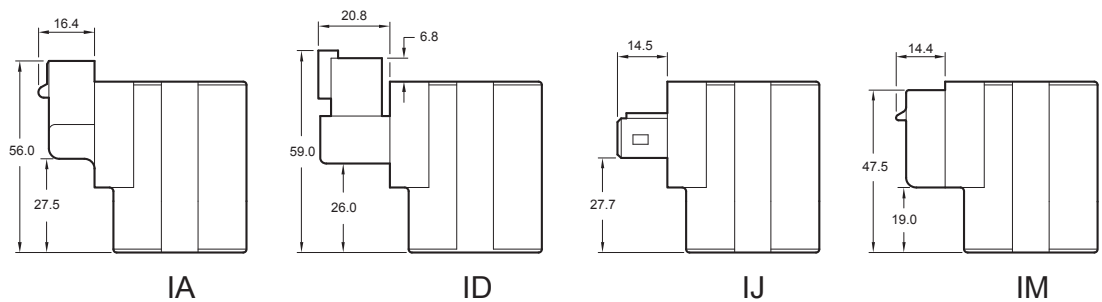

Ordering Code



Termination
IA - AMP superseal - Integral
ID - Deutsch - Integral DT04-2P
IJ - AMP Jr. Timer - Integral
IM - Metri-Pack - Integral

Voltage
12 - 12VDC - 2.2 Amp yellow lettering
24 - 24VDC - 1.1 Amp blue lettering

***Note** Pull type valves require nut PT-NTDE36202073 in lieu of standard nut.
Push type valves require nut PT-NTDE36202071 in lieu of standard nut.