



Up to 240 bar - 38 lpm

Operation

The D-DECVB allows free flow passage from (2) to (1), and blocks flow from (1) to (2).

The cartridge has a hardened ball, which is spring-biased closed, until sufficient pressure is applied at (2) to open to (1).

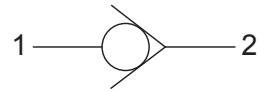
Symbol

Features

- Hardened parts for long life and low leakage.
- Industry common cavity.
- Optional bias springs for backpressure application flexibility.

Performance

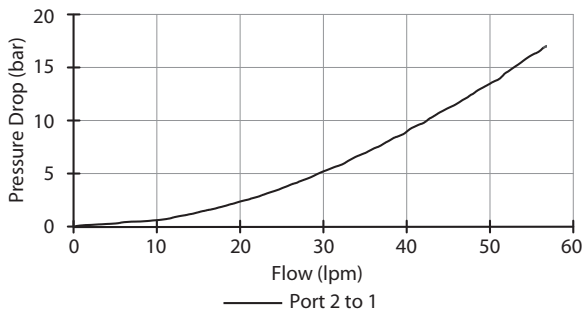
32 cSc / 38°C.

Specifications

Nom. Flow (lpm)	38
Max. Pressure (bar)	240
Internal Leakage (32 cSt)	0 to 0.25 cc/min
Hydraulic Oil	General purpose hydraulic fluid
Viscosity Range	3 to 640 cSt
Filtration	ISO 18/16/13
Operating Temp.	-40 to 120°C
Cartridge Torque	41 Nm
Cavity	DE10-2 (see cavity data page CAV-DE10-2)
Spare Seal Kit (Viton)	SK-DDEVHA
Weight - Valve only	0.06 kg
Weight - Valve + Body	0.29 kg (alum) 0.71 kg (steel)

Dimensions
[mm]

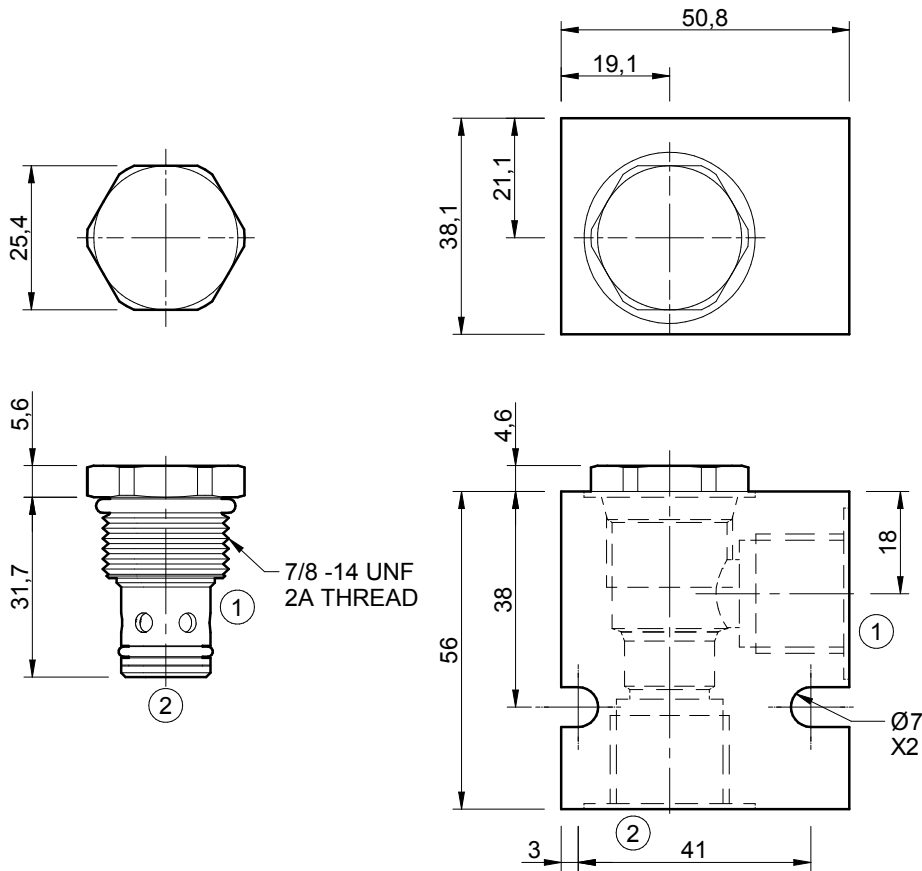

Ordering Code

