

Logic Elements.

Logic Valve, Bidirectional Type, Seat Ratio 1:2 - Size 16.

D-SLPLC

Up to 240 bar - Up to 150 lpm



This is a logic valve typically used for basic bidirectional blocking applications.

Operation

The D-SLPLC with an orifice between ports (3) and (1) maintains a constant flow rate from (3) regardless of load pressure changes in the system upstream of (3), or in the bypass leg at (2) as long as pressure at (2) is less than (1). Used for basic bidirectional blocking applications.

Symbol

Pilot to Close

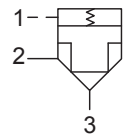

Features

- Hardened parts for long life
- Industry common cavity.



For metering see D-SLPCA or D-SLPCB.

Performance.

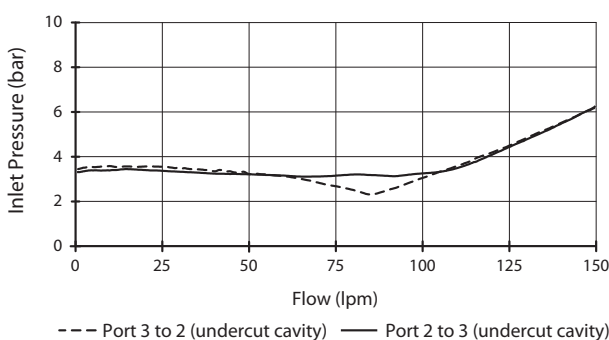
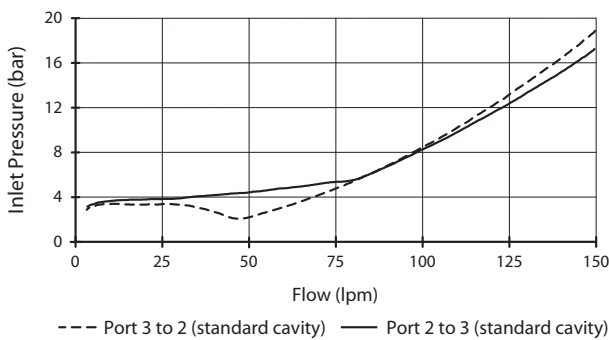

Valve Specifications

Nominal Flow (lpm)	150
Max. Pressure (bar)	240
Hydraulic Oil	General purpose hydraulic fluid
Viscosity Range	3 to 640 cSt
Filtration	ISO 18/16/13
Operating Temp.	-40 to 120°C
Cartridge Torque	122 Nm
Cavity	SL 16-3 (see cavity data page CAV-SL16-3)
Spare Seal Kit (Viton)	SK-DSLVHDA
Seat Ratio	Area of the Pilot is 2 times the area of the seat at Port 3
Weight - Valve only	0.29 kg
Weight - Valve + Body	0.97 kg (alum) 2.27 kg (steel)

Dimensions
[mm]

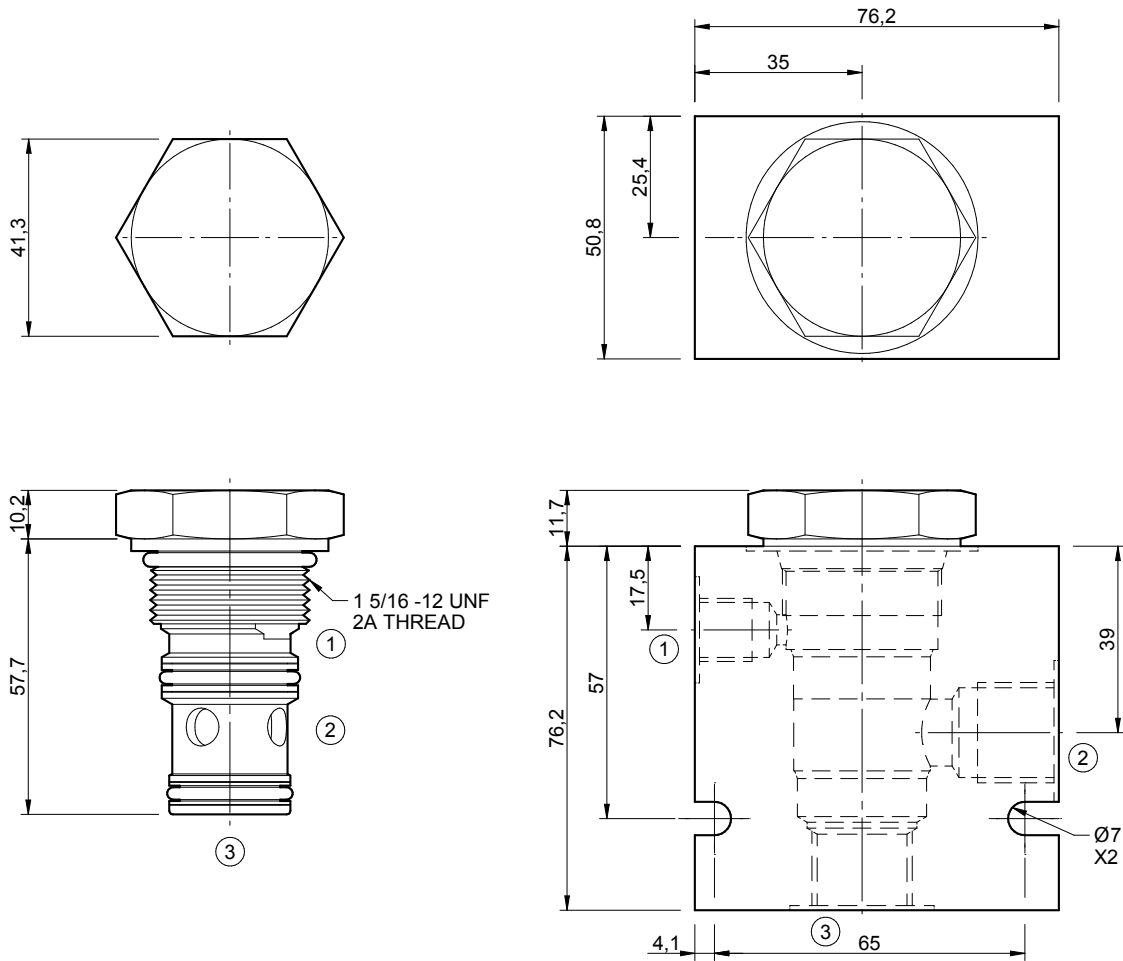

Ordering Code

D-SLPLC

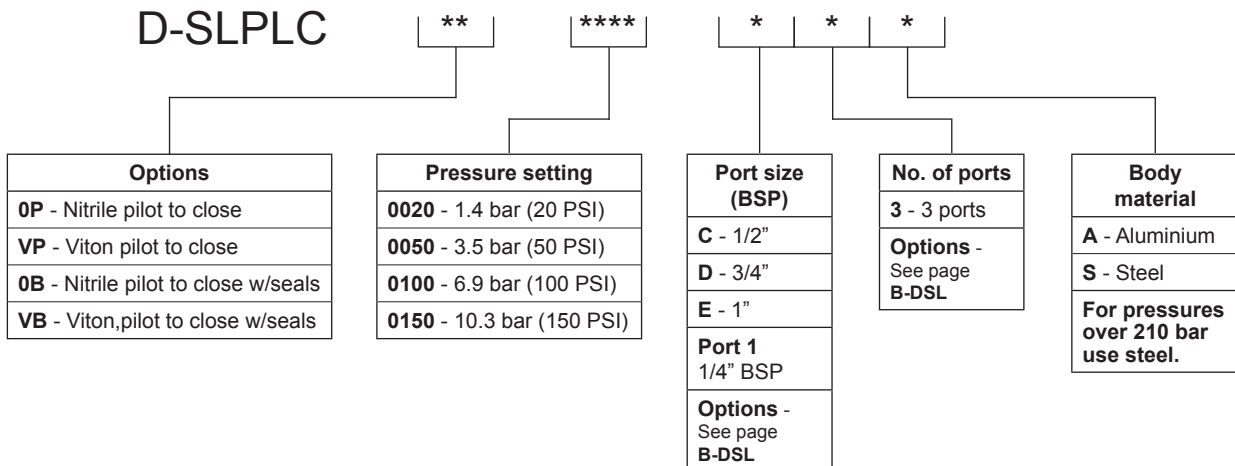

*Formerly DIN 43650 Hirschmann connector.