

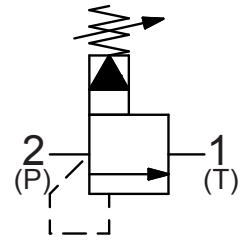

Up to 345 bar - 76 lpm

Symbol



This is a pilot operated spool type relief valve, typically used to provide main system relief protection. It is ideal for continuous duty and accurate stable pressure control with constant or varying flows.

Operation

The D-HTRVP blocks flow from (2) to (1) until sufficient pressure is present at (2) to force the pilot stage open, allowing the main stage spool to shift, opening (2) to (1).

Adjustment

Turn to increase pressure.

Features

- Hardened parts for long life.
- Industry common cavity.



This valve should not be used for service relief protection where load holding is required. In this case use a direct acting poppet style relief.

Performance

32 cSc / 38°C.

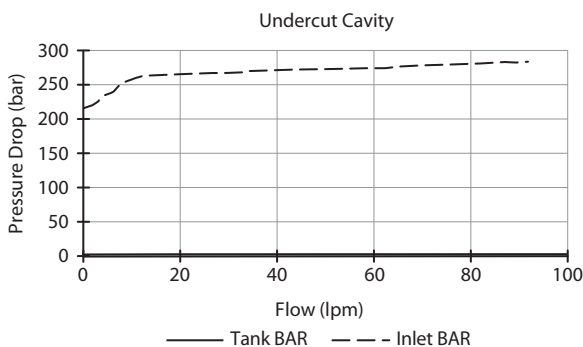
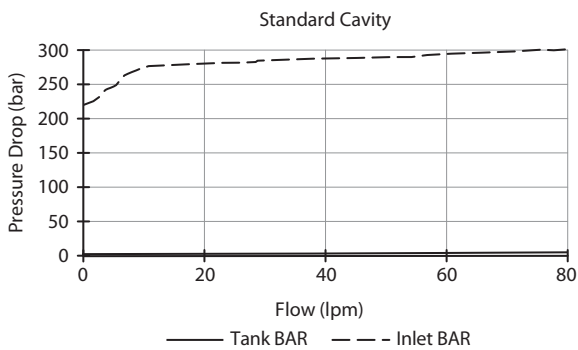

Specifications

Nom. Flow (lpm)	76
Max. Pressure (bar)	345
Hydraulic Oil	General purpose hydraulic fluid
Viscosity Range	3 to 640 cSt
Filtration	ISO 18/16/13
Operating Temp.	-40 to 120°C
Cartridge Torque	95 Nm
Cavity	TT12-2 (see cavity data page CAV-TT12-2)
Spare Seal Kit (Viton)	SK-DTTVHA
Weight - Valve only	0.51 kg
Weight - Valve + Body	1.09 kg (alum) 2.17 kg (steel)

Dimensions
[mm]

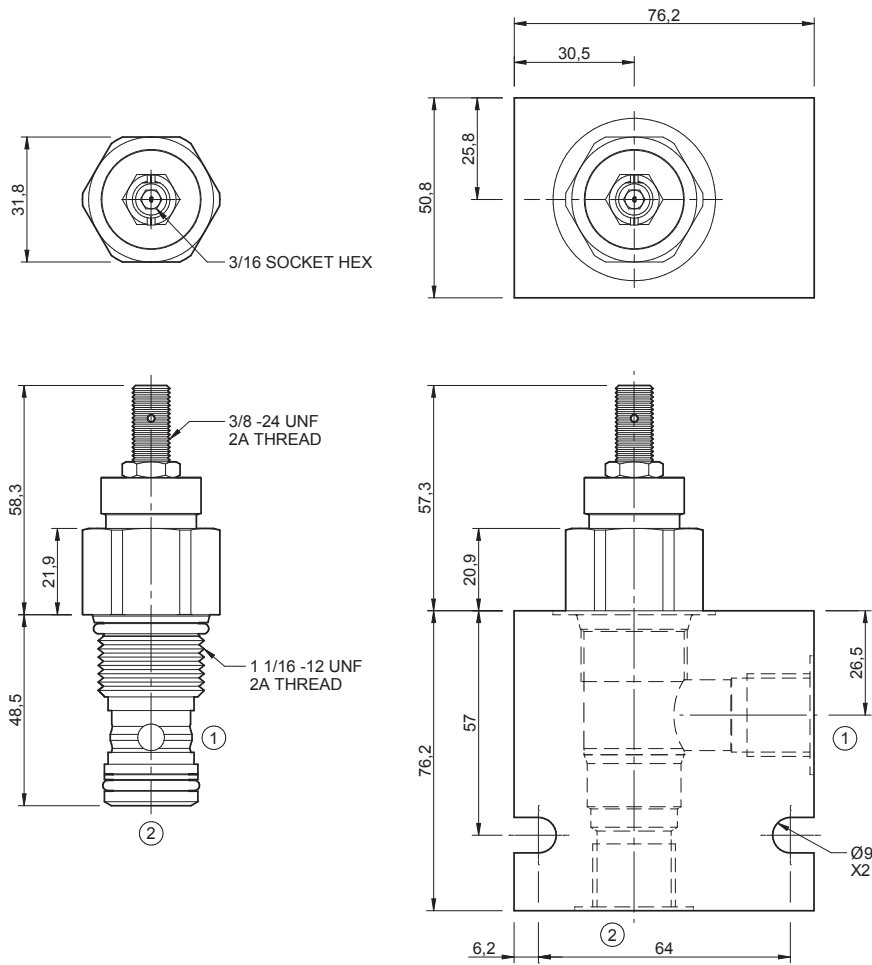

Ordering Code

