

7 size, 5/8-18 thread, "Mini" series

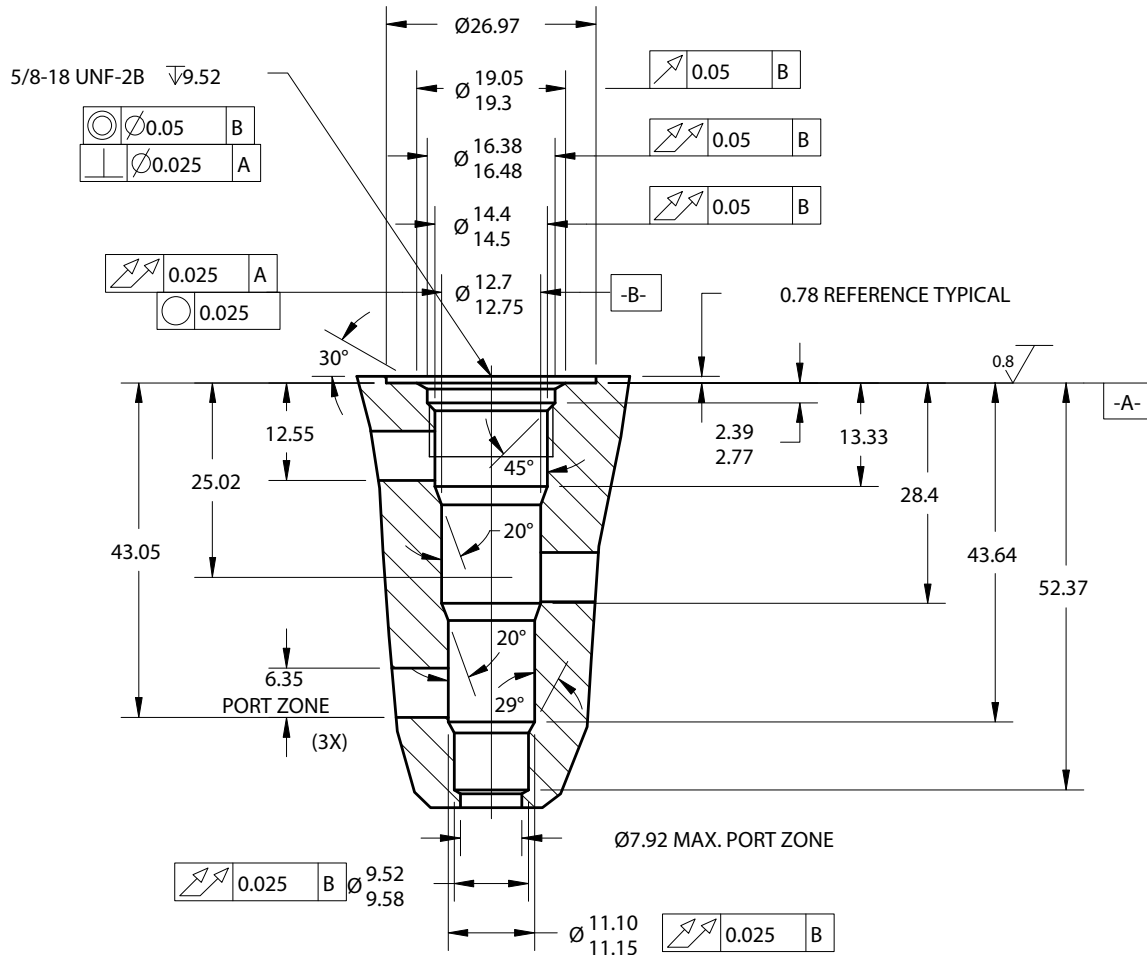

NOTES:

- 1.) CAVITY CAN BE MACHINED WITH
DELTA FORM TOOL #40500006.
- 2.) ALL MACHINED SURFACES TO BE 0.8
FINISH OR BETTER, EXCLUDING THREADS.
- 3.) IT IS VERY IMPORTANT THAT VALVE CAVITIES
MEET ALL DIMENSIONAL AND QUALITY
STANDARDS OF CONCENTRICITY AND PERPENDICULARITY.
THREADS MUST BE PERPENDICULAR TO THE SPOTFACE
SURFACE. SPOTFACE MUST CLEAN UP TO FULL DIAMETER.
IMPROPERLY MACHINED CAVITIES CAN LEAD TO CARTRIDGE
MALFUNCTION AND/OR FAILURE FROM DISTORTION.